



CANplus™ CP1000

Installation Manual

9M01-1000-A401-EN



CONNECT. CONTROL. PROTECT.

Revision History

VERSION	DATE	NOTES
A	12/2019	
B	12/2020	Document rebranded and contact information updated
C	03/03/2021	Updated signals for 31-position connector, corrected bracket image
D	06/06/2022	Corrected Aux Stop to show it as Normally Open

Any information furnished by Cattron™ and its agents is believed to be accurate and reliable. All specifications are subject to change without notice. Responsibility for the use and application of Cattron products rests with the end user since Cattron and its agents cannot be aware of all potential uses. Cattron makes no warranties as to non-infringement nor as to the fitness, merchantability, or sustainability of any Cattron products for any specific or general uses. Cattron Holdings, Inc., or any of its affiliates or agents shall not be liable for incidental or consequential damages of any kind. All Cattron products are sold pursuant to the Terms and Conditions of Sale, a copy of which will be furnished upon request. When used as a tradename herein, Cattron means Cattron Holdings, Inc. or one or more subsidiaries of Cattron Holdings, Inc. Cattron™, corresponding logos, and other marks are trademarks or registered trademarks of Cattron Holdings, Inc. Other marks may be the property of third parties. Nothing herein provides a license under any Cattron or any third party intellectual property right.



Contents

1	Introduction	4
2	Mechanical Mounting	5
2.1	AluFlex™ Panels	5
2.1.1	Mounting Templates	5
3	Connector Pinouts.....	8
3.1	D21 to Engine Pinout.....	8
3.2	D31 IO Pinout	9
4	Typical Wiring.....	10
4.1	Power and Ground.....	10
4.2	ECU Power Out	10
4.3	Starter Power Out	10
4.4	Resistive Senders	10
4.5	CAN Bus Termination	10
5	Testing.....	11
6	Certifications	12
6.1	FCC Part 15 Certification.....	12
6.2	Industry Canada Certification	13
7	Technical Support	14



1 Introduction

This manual provides general installation information for the CANplus™ CP1000. This manual's target audience is professional installers for Engine Distributors and OEMs of engine-driven machines. The engine manufacturer specific application information should be followed for any detailed or specific requirements. Cattron sales and technical support are available at www.cattron.com/contact to discuss specialized requirements or custom applications.



2 Mechanical Mounting

The CP1000 control panel is adaptable to a wide variety of applications. The included engine harness connector facilitates quick installation.

The following is a list of installation guidelines:

1. The panel mount shall be
 - a. Easily accessible by the operator.
 - b. Placed away from moving equipment.
 - c. Stable during equipment operation and transportation.
2. The vibration isolation mounts shall
 - a. Be properly installed.
 - b. Have normal movement.
 - c. Be located so the panel does not hit any adjacent structure during operation.

2.1 AluFlex™ Panels

AluFlex panel enclosures are constructed from extruded aluminum and powder-coated for durability. The faceplate is aluminum or powder-coated galvanized steel and the backplate is powder-coated galvanized steel. The enclosure is splash proof and includes condensation drain holes in the bottom.

AluFlex panel isolation mounts are preinstalled to a heavy-duty mounting bracket with mounting holes to accommodate various installations. Isolator mounts should not be twisted when installed, as doing so will lead to premature failure.

2.1.1 Mounting Templates

The following two figures (not to scale) show the one-to-one hole template for the CP1000 mounting bracket.



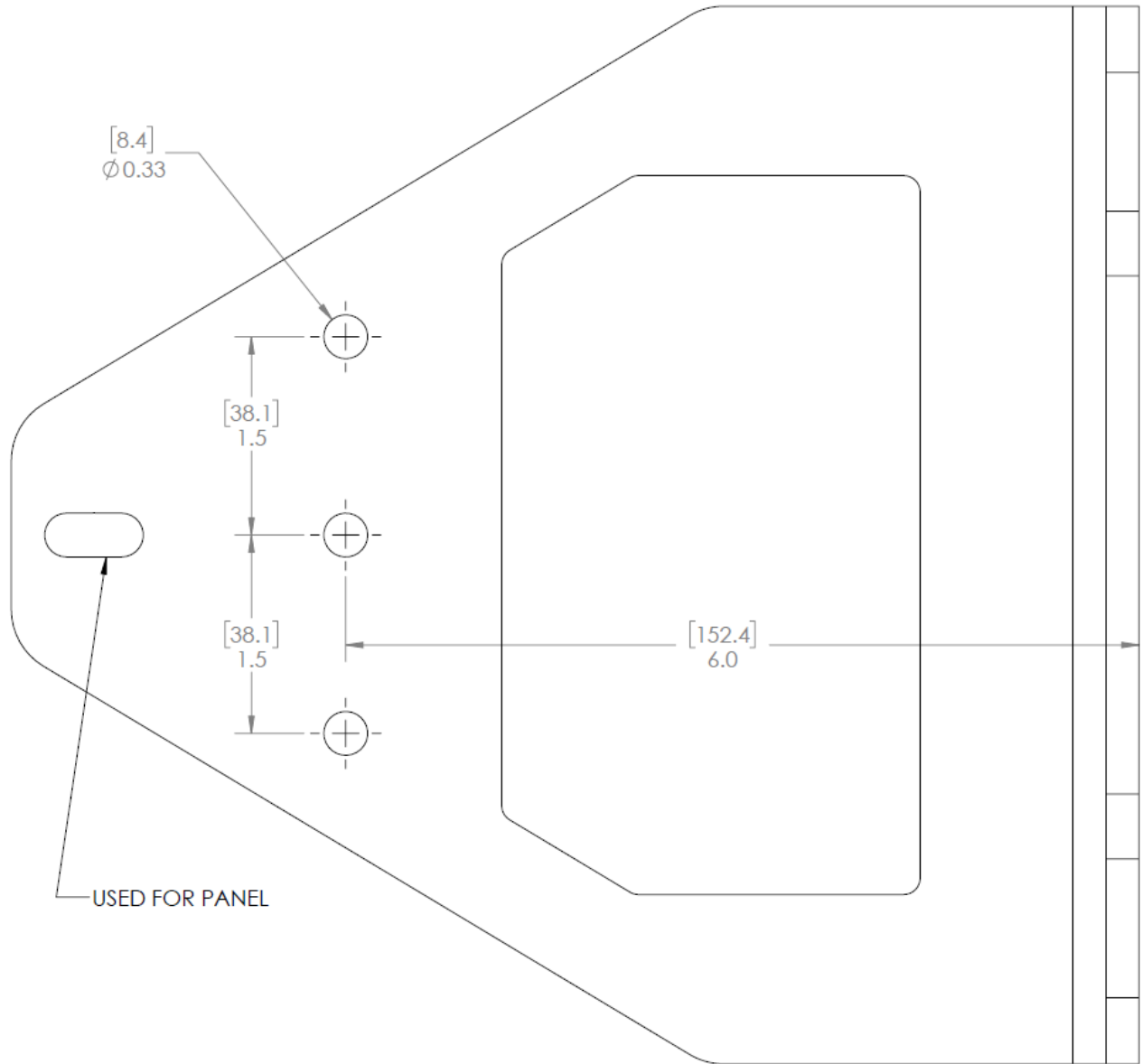

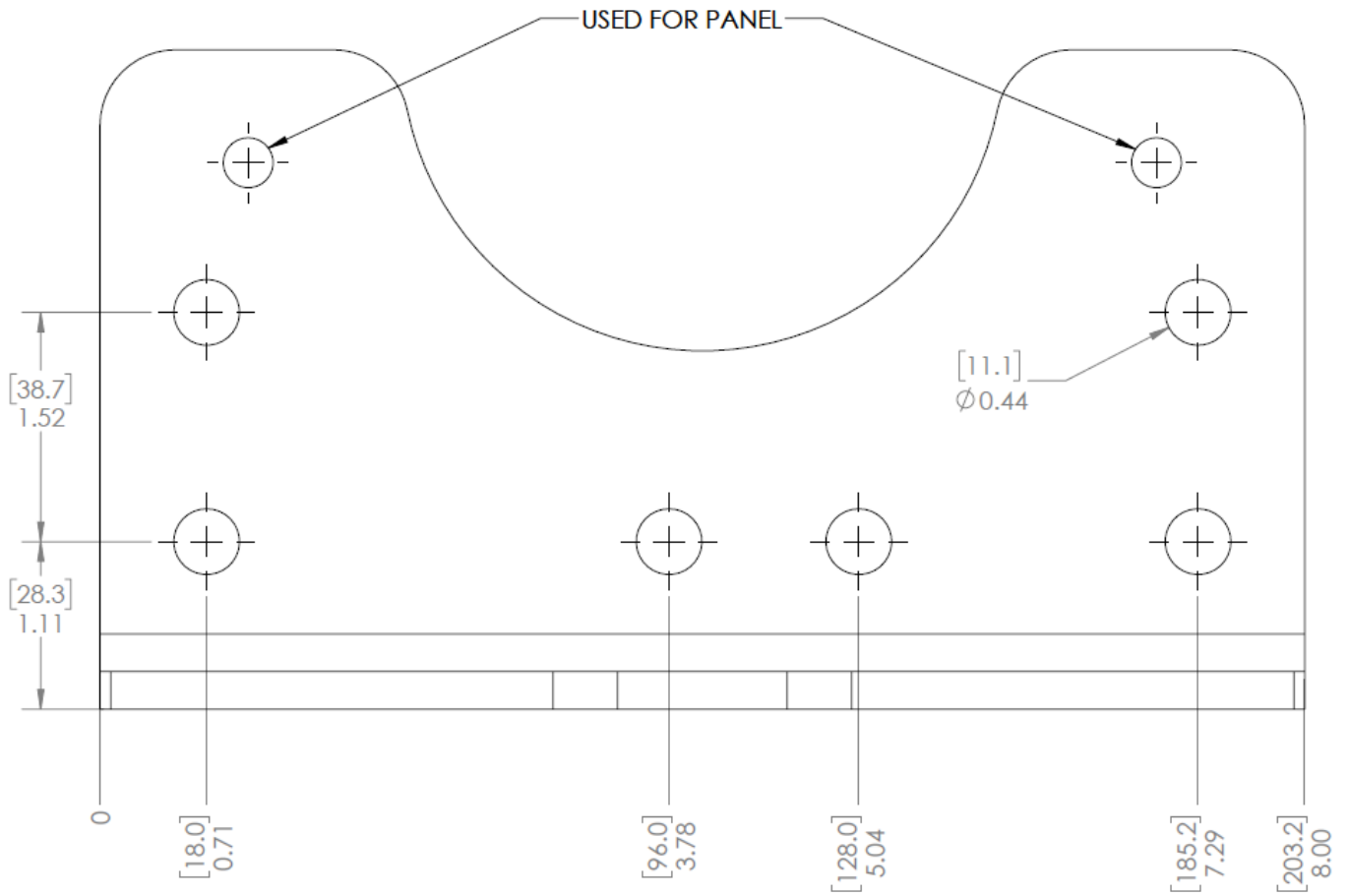

3 Connector Pinouts

There are two connectors on the CP1000, as described in the following subsections.

3.1 D21 to Engine Pinout

This connector contains the typical connections required for electronically or mechanically governed engines.

The following is the pinout:

Pin	Signal	Comment	Pin	Signal	Comment
A	Pre-Heat	1 A @ System Voltage	M	Aux IN 2	Active Low
B	B+		N	Temp SW	Active Low, Normally Open
C	Sender Return		P	Oil PSI Sender	System Voltage 0 – 750 Ω
D	Starter	10 A @ System Voltage	R	---	---
E	GND		S	Pulse2 Tach	System Voltage
F	CAN Shield		T	Oil PSI SW	Active Low, Normally Closed
G	ECU/Solenoid	10 A @ System Voltage	U	CAN Low	
H	Temp Sender	System Voltage 0 – 750 Ω	V	CAN High	
J	Ignition	1 A @ System Voltage	W	Aux IN 1	Active Low
K	Pulse Tach	System Voltage	X	Fuel Level Sender	System Voltage 0 – 750 Ω
L	---	---	---	---	---



3.2 D31 IO Pinout

This connector contains the CP1000's expanded IO.

The following is the pinout:

Pin	Signal	Comment	Pin	Signal	Comment
1	Aux SW 1	Active Low	17	Aux Out 3	1 A @ System Voltage
2	Aux SW 2	Active Low	18	Primary Transducer Power	1 A @ System Voltage
3	Aux SW 3	Active Low	19	Secondary Transducer Power	1 A @ System Voltage
4	Aux SW 4	Active Low	20	Pulse 1 A	
5	Aux SW 5	Active Low	21	Ground	
6	Aux SW 6	Active Low	22	Pulse 1 B	
7	Aux Out 1 Source	20 A	23	Aux Stop	Normally Open
8	Aux Out 1 Supply		24	Transducer 1	
9	Aux Out 1	20 A	25	Transducer 2	
10	Aux Out 1		26	Transducer 3	
11	Aux Out 2	10 A	27	Transducer 4	
12	Aux Out 2 Source	10 A	28	Transducer 5	
13	RS485 A		29	Transducer 6	
14	RS485 B		30	Autostart Switch 1	Active Low
15	Alarm/Buzzer Out	1 A @ System Voltage	31	Autostart Switch 2	Active Low
16	Aux Out 4	1 A @ System Voltage			



4 Typical Wiring

The following subsections describe the typical engine interface wiring.

4.1 Power and Ground

The panel's Power and Ground must connect directly to the battery posts and must not share power and ground wiring with any other devices, especially any high current loads. The Power line should have overcurrent protection in the form of current-limiting devices, fuses, circuit breakers or fusible links to protect the harness wiring in the event of fault conditions.

4.2 ECU Power Out

The CP1000 can directly power the engine ECU.

4.3 Starter Power Out

The Starter Power Out is intended to power the starter relay, which is required. When power is removed from the relay coil, the collapsing magnetic field generates a negative voltage surge. Negative voltage surges can damage components. The CP1000 has protection against these negative surges. However, it is still required to have a protection/suppression diode as close to the relay as possible. Cattron recommends the use of relays that have this protection/suppression diode built in. The protection/suppression diode must have sufficient voltage ratings to survive and sufficiently suppress these negative voltage surges. Cattron recommends a 1N4001 diode. Cattron sells a spike-suppressing diode kit (Part Number 630-4007-77).

4.4 Resistive Senders

The Resistive Sender connections send system voltage out to the sender to obtain the current value. It is required that the sender return connection be connected to a ground point (the engine chassis, for example), as close to the sender as possible in order to get an accurate measurement. If more than one sender is used, each sender should have a sender return connected to a ground point near that particular sender. All sender returns should then be connected together near the panel and the combined returns connected to the panel's sender return input.

4.5 CAN Bus Termination

CAN bus requires two 120 Ω termination resistors each at the extreme ends of the wiring harness. Typically, the engine ECU provides the termination resistor on its end (see the engine documentation to verify). The CP1000 has a termination resistor that can be turned off and on as needed. The CP1000's default configuration has this termination resistor turned on.



5 Testing



WARNING

DURING THE FOLLOWING PROCEDURE, CORRECT ANY PROBLEMS BEFORE PROCEEDING TO THE NEXT STEP. CONTINUED TESTING MAY DAMAGE THE PANEL, HARNESS OR ENGINE.

Use the following testing procedure:

1. Turning the keyswitch ON initiates self-test; check all connections and battery polarity on failure.
2. Test to verify overcurrent protection; identify and correct any wiring fault on failure.
3. Verify fuel run/stop solenoid or ECM energizes.
4. When the key is turned on, the fuel solenoid should be powered for until the display times out (configurable).
 - a. The ECM should send CAN bus data as soon as the self-test completes.
 - b. Verify engine cranks when the key is turned to start; check all connections on failure.
5. If the engine does not start, check the fuel lines and bleed if necessary.
6. Verify gauges and indicators with the engine running.
 - a. See the CP1000 User Manual for details.
7. Test all safety shutdowns.
 - a. See the CP1000 User Manual for details.
8. Run the engine for an extended time to identify any temperature or connection problems.



6 Certifications

6.1 FCC Part 15 Certification

This device complies with Part 15 of the FCC Rules. Operation is subject to the following two conditions: (1) this device may not cause harmful interference, and (2) this device must accept any interference received, including interference that may cause undesired operation.



WARNING

CHANGES OR MODIFICATIONS NOT EXPRESSLY APPROVED BY THE PARTY RESPONSIBLE FOR COMPLIANCE COULD VOID THE USER'S AUTHORITY TO OPERATE THE EQUIPMENT.

Note: This equipment has been tested and found to comply with the limits for a Class B digital device, pursuant to Part 15 of the FCC Rules. These limits are designed to provide reasonable protection against harmful interference in a residential installation. This equipment generates, uses and can radiate radio frequency energy and, if not installed and used in accordance with the instructions, may cause harmful interference to radio communications. However, there is no guarantee that interference will not occur in a particular installation. If this equipment does cause harmful interference to radio or television reception, which can be determined by turning the equipment off and on, the user is encouraged to try to correct the interference by one or more of the following measures:

- Reorient or relocate the receiving antenna.
- Increase the separation between the equipment and receiver.
- Connect the equipment into an outlet on a circuit different from that to which the receiver is connected.
- Consult the dealer or an experienced radio/TV technician for help.

This equipment uses the following Antennas and may not be used with other antenna types or with antennas of higher gain:

Mfg.: Pegasus Wireless Products

Type: Dipole

Gain: 3 dBi

This equipment complies with FCC RF Exposure requirements and should be installed and operated with a minimum distance of 20 cm between the radiator and any part of the human body.



6.2 Industry Canada Certification

Note: These statements are required to be listed in both English and French Languages.

This device complies with Industry Canada licence-exempt RSS standard(s). Operation is subject to the following two conditions: (1) this device may not cause interference, and (2) this device must accept any interference, including interference that may cause undesired operation of the device.

Le présent appareil est conforme aux CNR d'Industrie Canada applicables aux appareils radio exempts de licence. L'exploitation est autorisée aux deux conditions suivantes : (1) l'appareil ne doit pas produire de brouillage, et (2) l'utilisateur de l'appareil doit accepter tout brouillage radioélectrique subi, même si le brouillage est susceptible d'en compromettre le fonctionnement.

Under Industry Canada regulations, this radio transmitter may only operate using an antenna of a type and maximum (or lesser) gain approved for the transmitter by Industry Canada. To reduce potential radio interference to other users, the antenna type and its gain should be so chosen that the equivalent isotropically radiated power (e.i.r.p.) is not more than that necessary for successful communication.

Conformément à la réglementation d'Industrie Canada, le présent émetteur radio peut fonctionner avec une antenne d'un type et d'un gain maximal (ou inférieur) approuvé pour l'émetteur par Industrie Canada. Dans le but de réduire les risques de brouillage radioélectrique à l'intention des autres utilisateurs, il faut choisir le type d'antenne et son gain de sorte que la puissance isotrope rayonnée équivalente (p.i.r.e.) ne dépasse pas l'intensité nécessaire à l'établissement d'une communication satisfaisante.

This equipment complies with the ICES RF radiation exposure limits set forth for an uncontrolled environment. This equipment should be installed and operated with a minimum distance of 20 cm between the radiator and any part of the human body.

Cet équipement est conforme aux limites d'exposition aux radiations ICES définies pour un environnement non contrôlé. Cet équipement doit être installé et utilisé à une distance minimale de 20 cm entre le radiateur et une partie de votre corps.



7 Technical Support

For remote and communication control systems support, parts and repair, or technical support, visit us online at: www.cattron.com/contact.



Due to continuous product improvement, the information provided in this document is subject to change without notice.

Cattron Support

For remote and communication control systems support, parts and repair, or technical support, visit us online at:
www.cattron.com/contact

Cattron North America Inc., 655 N River Rd NW, Suite A, Warren, OH 44483